



DISHWASHER SRC-5000IS8CV 400/50/3N

183/275 baskets per hour (up to 4.950 plates/hour).



P/N 1302822

- ✓ Automatic boiler filling with no failure risk for heating elements.
- ✓ Temperature control with high precision probes.
- ✓ Visualisation and adjustment of washing and rinsing temperatures in the digital display by pressing a button.
- ✓ Easy to install rinse aid dispenser intake in boiler.

INCLUDES

- ✓ Inlet and outlet splash guards are standard.
- ✓ Extraction hood with steam condensation CV.
- ✓ Drying unit TS-800.

OPTIONAL

- Inlet tables and compositions.
- Outlet tables and compositions.

ACCESSORIES

- Manual water softeners
- Automatic water softeners
- 500 x 500 mm. baskets
- Inserts & supplements
- Loading table for corner situation for rack conveyor dishwashers
- Central sorting tables
- Double connection central sorting table
- Single exit tables
- Roller conveyor and corner roller conveyor
- Machined curve
- Connecting tables for pass-through dishwashers and rack conveyors

SPECIFICATIONS

Production

- ✓ Production baskets/hour: 183 / 275
- ✓ Production plates/hour: 3294 / 4950

Pre-wash

- ✓ Temperature: 35 °C - 45 °C
- ✓ Pre-wash basin capacity: 60 l
- ✓ Pump: 1.2 Hp / 880 W

First wash

- ✓ Temperature: 55 °C - 65 °C
- ✓ 1st wash tank capacity: 60 l
- ✓ Pump: 1.2 Hp / 880 W
- ✓ 1st wash heating element: 6000 W

Boosted wash

- ✓ Temperature: 55 °C - 65 °C
- ✓ Wash tank capacity: 100 l
- ✓ Pump: 3.5 Hp / 2600 W
- ✓ Wash heating element: 9000 W

Pre-rinse

- ✓ Temperature: 65 °C - 75 °C
- ✓ Pre-rinse basin capacity: 15 l
- ✓ Pump: 0.2 Hp / 0.15 W
- ✓ Pre-rinse heating element: 6000 W

Rinse

- ✓ Temperature: 80 °C - 90 °C
- ✓ Water consumption: 480 l/h
- ✓ Rinse heating element: 27000 W
- ✓ Boiler capacity: 20 l



SALES DESCRIPTION

Pre-washing + first washing + enhanced washing + double rinsing.
2 speeds.

- ✓ Fully stainless steel jacket.
- ✓ Inlet and outlet splash guards are standard.
- ✓ Stainless steel central rack feed system.
- ✓ Process cycles are divided by rubber curtains.
- ✓ Automatic cycle start.

Economy

- ✓ Energy saving rinse supply switch.
- ✓ Pressure controller in the rinse section to limit consumption.
- ✓ Programmed automatic stops if there is no loading.
- ✓ Stop and freezing of timer when the limit switch actuates.

Cleaning and maintenance

- ✓ Wide pivoting door allowing access for cleaning or inspection purpose.
- ✓ Detachable arms and dispersers for easier cleaning.
- ✓ Sloped removable stainless steel filters with independent removable basket.
- ✓ Easy boiler emptying by loosening a hose.
- ✓ Failures are easily detected thanks to the warning lights.
- ✓ Easy to repair without moving the machine.

Washing

- ✓ Stainless steel wash arms and deep-drawn dispersers.
- ✓ Efficient and durable wash arm dispersers.
- ✓ Powerful, self-draining vertical wash pump.
- ✓ Easy to install detergent dispenser intake in washing tank. Rinsing

Rinsing

- ✓ Stainless steel rinse arms and powerful, stainless steel, deep-drawn dispersers.

WARE WASHING
RACK CONVEYOR DISHWASHERS

product sheet
updated 15/02/2023





DISHWASHER SRC-500IS8CV 400/50/3N

183/275 baskets per hour (up to 4.950 plates/hour).

P/N 1302822

Drag

✓ Drag motor power: 0.25 Hp / 180 W

Drying

- ✓ Air flow: 2000 m³/h
- ✓ Fan power: 1,5 Hp / 750 W
- ✓ Dryer heater element: 9000 W

Mist condenser

- ✓ Fan power CV (HP): 0,75 Hp
- ✓ Fan power CV (W): 550 W

Loading

✓ Total installed power: 52790 W

Electrical supply: 400 V / 50 Hz / 3N ~

Electrical connection: 3P+N+G

External dimensions (WxDxH)

- ✓ Width: 4100 mm
- ✓ Depth: 829 mm
- ✓ Height: 1940 mm

Net weight: 695 Kg

Water Intake: 3/4 "

Drain diameter: 1 1/2 "

Noise level (1m.): 71 dB(A)

Crated dimensions

4370 x 980 x 2000 mm
Gross weight: 760 Kg

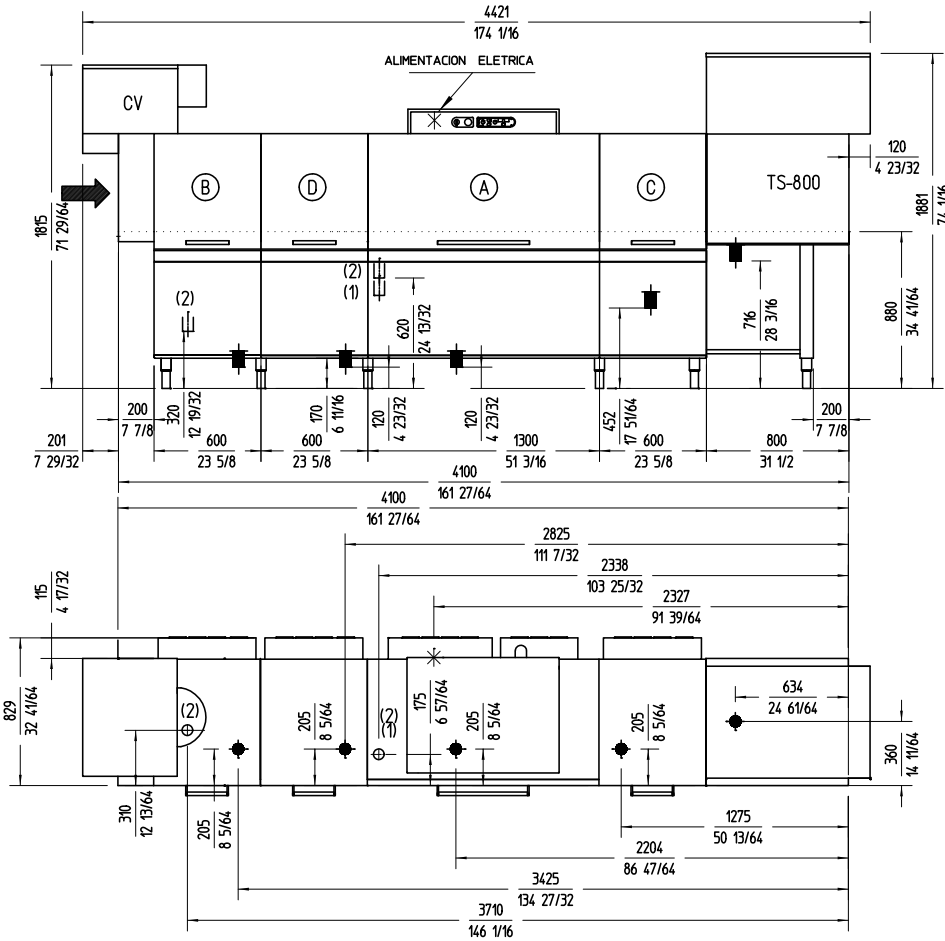

WARE WASHING
RACK CONVEYOR DISHWASHERS

sammic | www.sammic.com
Food Service Equipment Manufacturer

Polígono Basarte, 1. phone +34 943 15 72 36
20720 Azkoitia, Spain sales@sammic.com



Project	Date
Item	Qty
Approved	

product sheet
updated 15/02/2023