



VACUUM PACKING MACHINE SU-420P 230/50-60/1

Tabletop model. 20 m³/h. 420 mm.



P/N 1140774



SALES DESCRIPTION

420 mm. sealing bar.
20 m³/h Busch vacuum pump.
Vacuum controlled by sensor.

- ✓ Powered by Busch.
- ✓ Vacuum controlled by sensor.
- ✓ Vacuum PLUS.
- ✓ LCD colour screen: all information at a glance.
- ✓ Backlit touch keyboard.
- ✓ Programmable: 25-programme memory. Blocking option.
- ✓ "Pause" button.
- ✓ Phased vacuum programme.
- ✓ Detection of the evaporation of liquids.
- ✓ Double seal.
- ✓ Cordless sealing bar.
- ✓ Progressive decompression.
- ✓ Vac-Norm ready with Automatic decompression.
- ✓ Stainless steel body and chamber. Deep-drawn chamber.
- ✓ Damped transparent lid.
- ✓ Dry-oil programme for drying the pump.
- ✓ Working hours counter for oil changes.
- ✓ Safety system with protection against vacuum failure.

INCLUDES

- ✓ Filling plate
- ✓ Printer connection
- ✓ Wireless connectivity

OPTIONAL

- Printer
- Vacuum packing pouches
- Vac-Norm external vacuum kit, containers and accessories
- Bag cutting kit
- Support for liquids
- Additional filling plates

ACCESSORIES

- Bag cutting kits
- Filling plates
- Liquid insert plates
- Vac-norm external vacuum kits
- Vac-norm containers
- Smooth bags for vacuum packing
- Trolley for vacuum packing machines
- Thermal labels for CG2 / RB printer
- RB desktop printer for SU vacuum packing machines
- Thermal transfer labels for RB printer

SPECIFICATIONS

Pump capacity: 20 m³/h
 Pump capacity (60 Hz): 24 m³/h
 Bar length: 420 mm
 Total loading: 750 W
 Vacuum pressure (maximum): 2 mbar
 Electrical supply: 230 V / 50-60 Hz / 1~ (5.5 A)
 Plug: EU (SCHUKO 2P+G)

Internal dimensions

- ✓ Width: 430 mm
- ✓ Depth: 415 mm
- ✓ Height: 180 mm

External dimensions (W x D x H)

- ✓ Depth: 529 mm
- ✓ Height: 448 mm (230V) / (120V)
- ✓ Width: 484 mm
- ✓ Depth: 529 mm
- ✓ Height: 448 mm

Net weight: 56.7 kg

Noise level (1m.): 75 dB(A)
 Background noise: 32 dB(A)

Crated dimensions

600 x 600 x 610 mm
 Gross weight: 65.1 kg

FOOD PRESERVATION AND SOUS-VIDE
VACUUM PACKING MACHINES • SENSOR ULTRA LINE

product sheet
updated 23/05/2024



SAMMIC S.L.
Basarte, 1 - 20720 AZCOITIA
www.sammic.com



VACUUM PACKING MACHINE SU-420P 230/50-60/1

Tabletop model. 20 m³/h. 420 mm.



P/N 1140774

FOOD PRESERVATION AND SOUS-VIDE
VACUUM PACKING MACHINES • SENSOR ULTRA LINE

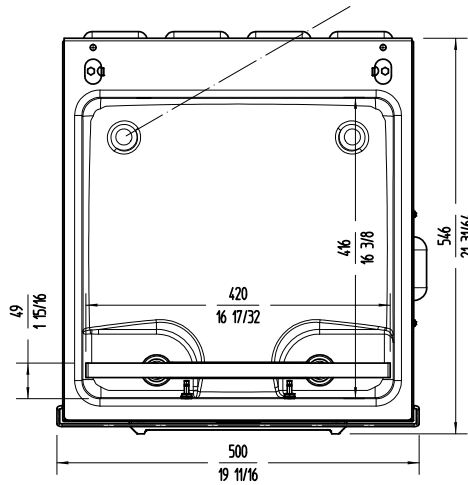
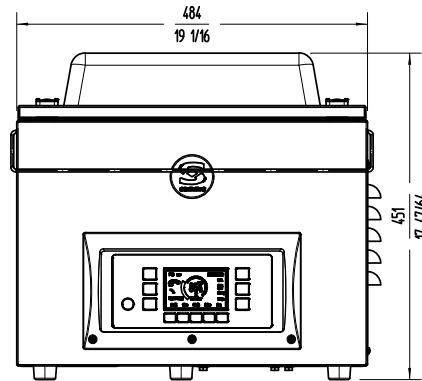
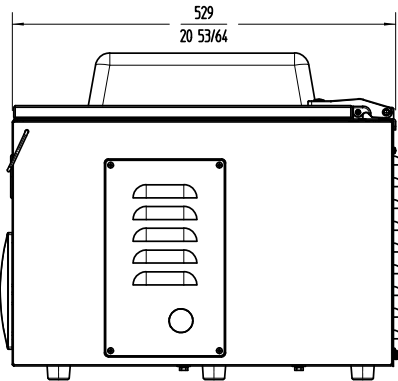

sammic | www.sammic.com
Food Service Equipment Manufacturer
Polígono Basarte, 1. phone +34 943 15 72 36
20720 Azkoitia, Spain sales@sammic.com



Project	Date
Item	Qty
Approved	

product sheet
updated 23/05/2024