



VACUUM PACKING MACHINE SU-6100GP+ 400/50-60/3N

Double chamber vacuum packing machine. 100m³/h.



P/N 1141038

FOOD PRESERVATION AND SOUS-VIDE
VACUUM PACKING MACHINES • SENSOR ULTRA LINE



SALES DESCRIPTION

High performance model with tilting cover, double chamber and 4 x 662 mm. sealing bars. 100 m³/h Busch vacuum pump. Vacuum controlled by sensor.

- ✓ Powered by Busch.
- ✓ Vacuum controlled by sensor.
- ✓ Vacuum PLUS.
- ✓ LCD colour screen: all information at a glance.
- ✓ Backlit touch keyboard.
- ✓ Programmable: 25-programme memory. Blocking option.
- ✓ "Pause" button.
- ✓ Phased vacuum programme.
- ✓ Detection of the evaporation of liquids.
- ✓ Double seal.
- ✓ Cordless sealing bar.
- ✓ Progressive decompression.
- ✓ Stainless steel body and chambers.
- ✓ Tilting cover made of thick, robust stainless steel.
- ✓ Dry-oil programme for drying the pump.
- ✓ Working hours counter for oil changes.
- ✓ Safety system with protection against vacuum failure.

INCLUDES

- ✓ 4 filling plates
- ✓ Inert gas flush (2 x (4+4) injectors).
- ✓ Wireless connectivity
- ✓ Printer connection
- ✓ "Plus" sealing system

OPTIONAL

- Printer
- Vacuum packing pouches
- Vac-Norm external vacuum kit, containers and accessories
- Bag cutting kit
- Support for liquids
- Additional filling plates

ACCESSORIES

- Bag cutting kits
- Filling plates
- Liquid insert plates
- Smooth bags for vacuum packing
- Thermal labels for CG2 / RB printer
- RB desktop printer for SU vacuum packing machines
- Thermal transfer labels for RB printer

SPECIFICATIONS

Pump capacity: 100 m³/h
 Bar length: 662 mm + 662 mm
 Total loading: 2200 W
 Vacuum pressure (maximum): 0.5 mbar
 Electrical supply: 400 V- / 50-60 Hz / 3N~ (8.7 A)
 Electrical connection: 3P+N+G

Internal dimensions

- ✓ Width: 662 mm
- ✓ Depth: 656 mm
- ✓ Height: 205 mm

External dimensions (W x D x H)

- ✓ Width: 1640 mm
- ✓ Depth: 874 mm
- ✓ Height: 1370 mm

Net weight: 366 kg
 Noise level (1m.): 75 dB(A)
 Background noise: 32 dB(A)

Crated dimensions

980 x 1720 x 1280 mm
 Gross weight: 414 kg



product sheet
updated 15/03/2024



VACUUM PACKING MACHINE SU-6100GP+ 400/50-60/3N

Double chamber vacuum packing machine. 100m³/h.



P/N 1141038

FOOD PRESERVATION AND SOUS-VIDE
VACUUM PACKING MACHINES • SENSOR ULTRA LINE

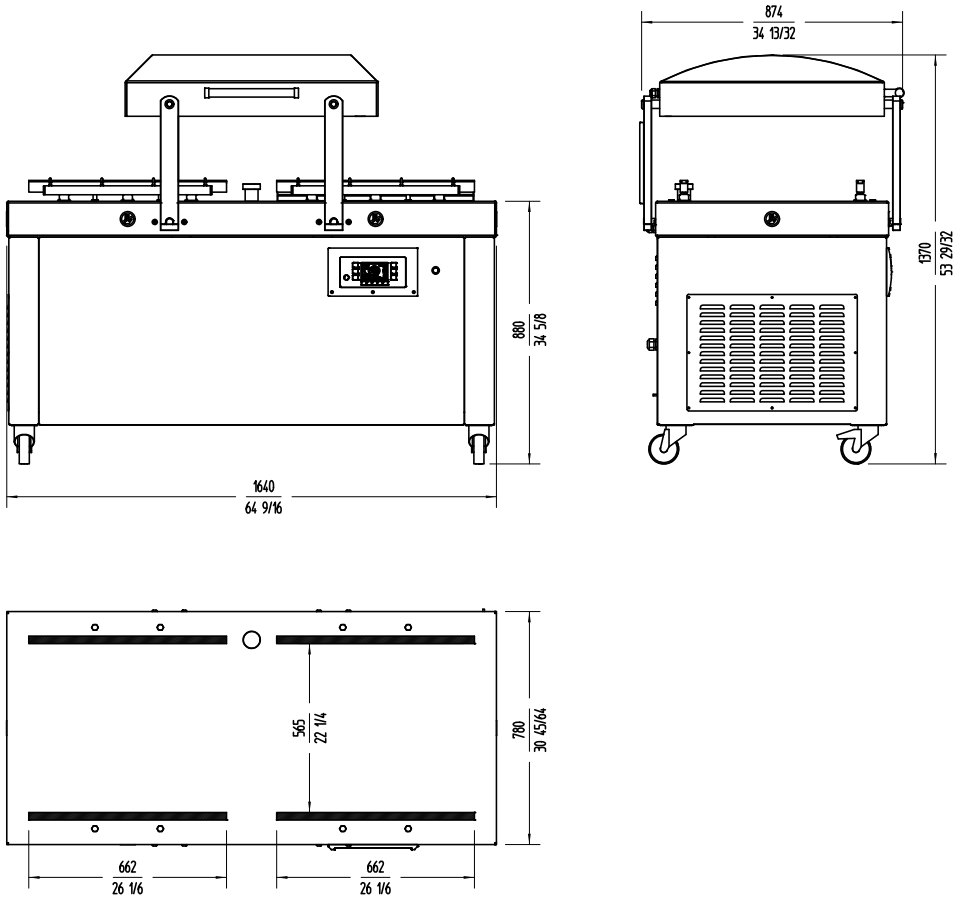

sammic | www.sammic.com
Food Service Equipment Manufacturer

Polígono Basarte, 1. phone +34 943 15 72 36
20720 Azkoitia, Spain sales@sammic.com



Project	Date
Item	Qty
Approved	

product sheet
updated 15/03/2024