

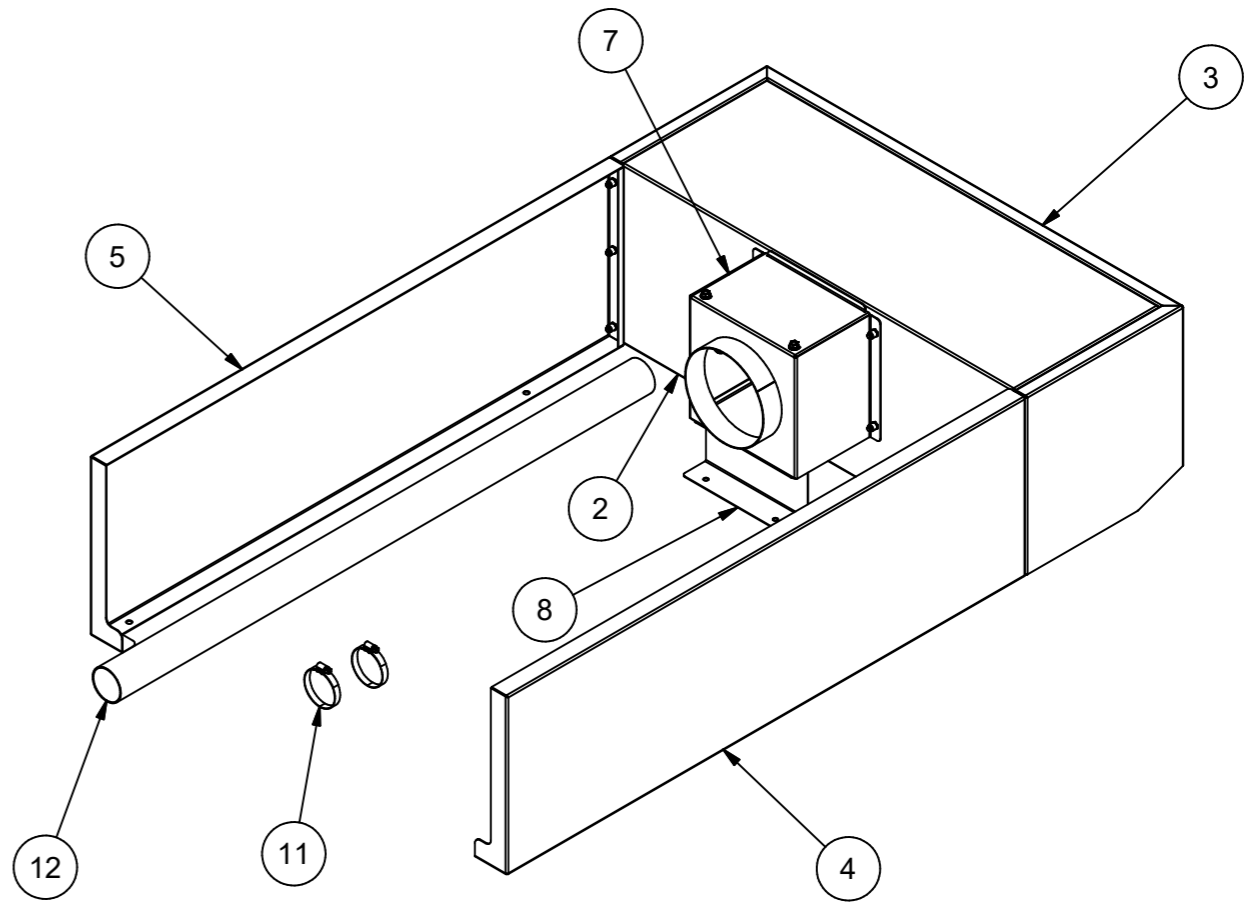

PARTS LIST			
ITEM	PART NUMBER	DESCRIPTION	QTY
1	153-14-05500	BAFFLE PLATE	1
2	153-14-05700	CANOPY REAR	1
3	153-14-05800	CANOPY FACE	1
4	153-14-05900	CANOPY SIDE - LH	1
5	153-14-05901	CANOPY SIDE - RH	1
7	158-14-13800	DUCTING BOX ASSY	1
8	158-14-14000	FRONT CONNECTION BRKT	1
9	A900-03-045	HEX HEAD SERRATED SCREW M6x16, STAINLESS STEEL	18
11	A900-01-271	WORM DRIVE CLIP	2
12	A900-23-027	ALUMINIUM DUCT HOSE 50mm ID x 1M LONG	1

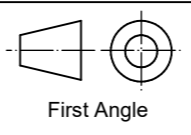

A H:\MASTER FOLDER\153\FG153-AC5.iam
 Copyright © 2001 - This drawing/design is the property of Mono equipment and must not be reproduced, copied, nor its contents divulged without prior written permission
 Remove all burrs and sharp edges - on sheet metal external corners to be safety radiused 2mm unless stated otherwise
 Surface machining: $\frac{3.2}{\sqrt{\text{mm}}}$ Coarse finish $\frac{1.6}{\sqrt{\text{mm}}}$ Medium finish $\frac{0.8}{\sqrt{\text{mm}}}$ Fine finish $\frac{0.4}{\sqrt{\text{mm}}}$ Ground finish
 Open tol, 150 & below +/-0.5, over 150 +/-1 Decimal dim's, 75 & below +/-0.25, 75 to 300 +/-0.4, 300 to 600 +/-0.5, over 600 +/-1



 QUEENSWAY SWANSEA WEST IND. PARK SWANSEA SA5 4EB TEL 01792 561234 FAX 01792 561016		TITLE EXTRACTION CANOPY	
MATL DESCRIPTION (MONO REF.)		DRAWN AD	PURCHASE ORDER NO.
FINISH		DATE 20/01/2022	WORKS ORDER NO.
MATL QTY		SHEET SIZE A3	DRG NO. FG153-AC5
			REV -