



# GLASSWASHER UX-40SBC 230/50/1 DD

Rack size 400x400mm and door clearance 300 mm. Constant temperature rinsing system and double-skinned construction.

P/N 1303148



WARE WASHING  
COMMERCIAL GLASSWASHERS

## SALES DESCRIPTION

Sani-Control: guaranteed disinfection.  
Embedded bodywork and easy-grip door: hygienic and ergonomic.  
Double-walled body: insulation and energy efficiency.  
Exclusive Hydroblade™ washing arms: maximum effectiveness.  
3-stage filtering system.

### Sani-Control guarantee

- ✓ GUARANTEED DISINFECTION in compliance with standard DIN 10534.
- ✓ THERMAL LOCK function: Ensures that rinsing will be carried out at the ideal temperature to disinfect the dishes.
- ✓ CONSTANT HIGH TEMPERATURE RINSE system for optimal disinfection.
- ✓ The PRESSURE PUMP guarantees effective high-pressure rinsing.

### New recessed bodywork

- ✓ Ergonomic design with rounded corners to prevent the accumulation of dirt and facilitate cleaning.
- ✓ Compact tank volume (50% water saving compared to the previous range).
- ✓ Embedded basket guides

### Double-Walled (Ultra ISO)

- ✓ Double-Walled Structure: thermo-acoustic insulation to attenuate the sound level and improve energy efficiency.

### Hydroblade™ washing arms

- ✓ Redesigned nozzles for greater washing performance.
- ✓ The “monoblock” design delivers durability and resistance to impacts.
- ✓ 30% savings in water consumption during rinsing compared to the previous range.

### 3-stage filter system: surface, tank and extraction

- ✓ Keeps the washing water in optimal conditions to maintain constant washing performance.
- ✓ The surface filters feature an “easy-on” design and can be quickly removed without having to disconnect the washing arms.

### “Easy grip” door: new design with integrated door handle

- ✓ The integration of the components provides greater resistance and robustness.
- ✓ Designed to have no corners or areas that are difficult to access: prevents deposits of dirt and facilitates cleaning.
- ✓ Its ergonomic handle provides a perfect grip, even with wet hands.
- ✓ Double-walled door with safety microswitch and high quality seal
- ✓ 30 cm load capacity: high versatility for washing a wide range of glasses and even medium-sized dishes.

### Premium warewashing

- ✓ Ultra Xperience: high performance, without complications.
- ✓ Soft start: progressive start-up of the washing pump to protect fragile items.
- ✓ Colour LCD Display: intuitive communication of the machine status by means of messages, colour codes and icons.
- ✓ Dedicated cycles: selection of the ideal washing programme using icons.
- ✓ Adaptable: allows the main parameters of the machine to be adjusted to the needs of each user.
- ✓ TEMPERATURE DISPLAY
- ✓ Wash Plus+ function: increases the intensity of the wash cycle for greater cleaning performance
- ✓ Control panel with IP65 humidity protection.

### You will never WASH ALONE

- ✓ Tech-Services: our team of technicians will help you so that your machine is always ready for use.
- ✓ Design Services: tell us what your needs are and we will advise you.
- ✓ 60 years of experience and know-how at your disposal.

## INCLUDES

- ✓ Drainage pump with level sensor. Proactive tank water renewal.
- ✓ Detergent Dispenser.
- ✓ 1 glasses basket.
- ✓ 1 mixed basket (plates).
- ✓ 1 small basket for cutlery.

## OPTIONAL

- Manual resin regeneration water softener.
- Double-level accessory for washing two baskets at the same time.

## SPECIFICATIONS

Basket dimensions: 400 mm x 400 mm

Maximum glass height: 300 mm

Cycle duration: 90 / 120 / 150 / 180 “

Production baskets/hour: 40 / 30 / 24 / 20

Boiler capacity: 4.5 l

Wash tank capacity: 9 l

### Consumption and savings

Water consumption/cycle: 1.9 l

Automatic saving mode in: 25 ‘

Automatic switch-off: 120 ‘

### Loading

- ✓ Pump: 250 W / 0.33 Hp

- ✓ Tank: 1200 W





# GLASSWASHER UX-40SBC 230/50/1 DD

Rack size 400x400mm and door clearance 300 mm. Constant temperature rinsing system and double-skinned construction.



P/N 1303148

- ✓ Boiler: 2500 W
- ✓ Total loading: 2750 W
- Electrical supply: 230 V / 50 Hz / 1 ~ (12 A)

### External dimensions (WxDxH)

- ✓ Width: 470 mm
- ✓ Depth: 540 mm
- ✓ Height: 710 mm

Net weight: 42 Kg  
Noise level (1m.): -- dB(A)

**Crated dimensions**  
525 x 615 x 820 mm  
Gross weight: 48 Kg

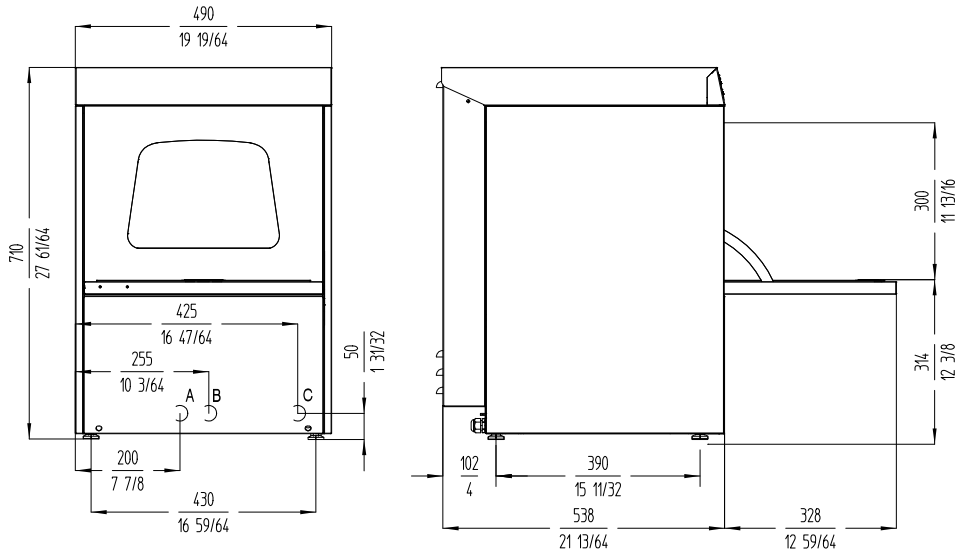

A: Entrada de agua 3/4" GAS.  
B: Tubo de desague Ø30 mm.  
C: Cable conexión

WARE WASHING  
COMMERCIAL GLASSWASHERS

**sammic** | www.sammic.com  
Food Service Equipment Manufacturer

Polígono Basarte, 1. phone +34 943 15 72 36  
20720 Azkoitia, Spain sales@sammic.com



Project	Date
Item	Qty
Approved	

product sheet  
updated 09/01/2023