



MEAT MINCER PS-12 230/50/1

Hourly output: up to 100 Kg.



P/N 1050110



- ✓ Height: 410 mm
- Net weight: 17.3 Kg
- Noise level (1m.): <70 dB(A)
- Background noise: 32 dB(A)

Crated dimensions
 340 x 480 x 340 mm
 Gross weight: 18.9 Kg

DYNAMIC PREPARATION
COMMERCIAL MEAT GRINDERS

SALES DESCRIPTION

- ✓ Motor unit and cutting unit in aluminium.
- ✓ System: Enterprise.
- ✓ 1 knife and a Ø 6 mm. mesh plate included.

Ideal for foodservice, communities and food retailers.

- ✓ Body and hopper in stainless steel.
- ✓ Mincing head blockage that ensures a perfect cut.
- ✓ Sturdy and ventilated motor.

INCLUDES

- ✓ Enterprise system, aluminium cutting unit.
- ✓ Ø 6mm. mesh plate.

OPTIONAL

- Mesh plates of different sizes: 4.5 / 6 / 8 mm.

ACCESSORIES

- Mesh plates

SPECIFICATIONS

Production /hour (max): 100 Kg
 Plate diameter: 70 mm
 Inlet mouth diameter (1) : 45 mm
 Electrical supply: 230 V / 50 Hz / 1 ~ (3 A)
 Plug: EU (SCHUKO 2P+G)
 Total loading: 440 W

External dimensions (WxDxH)

- ✓ Width: 227 mm
- ✓ Depth: 470 mm



product sheet
updated 06/06/2023



MEAT MINCER PS-12 230/50/1

Hourly output: up to 100 Kg.



P/N 1050110

DYNAMIC PREPARATION
COMMERCIAL MEAT GRINDERS

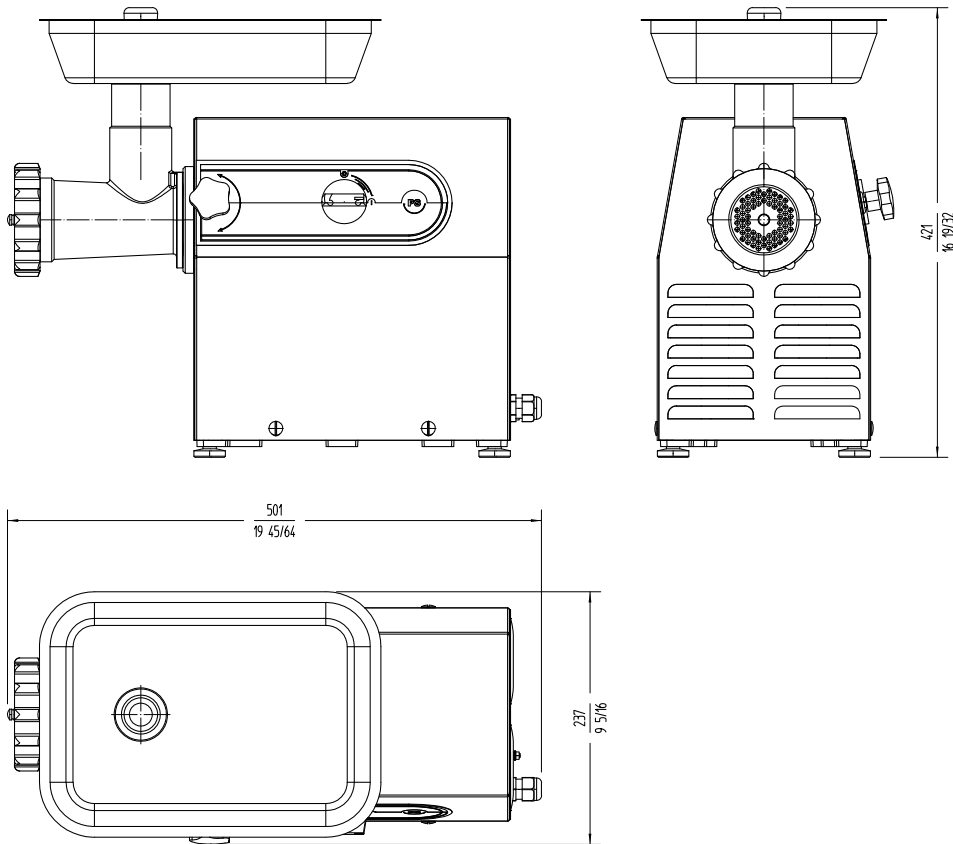

sammic | www.sammic.com
Food Service Equipment Manufacturer

Polígono Basarte, 1. phone +34 943 15 72 36
20720 Azkoitia, Spain sales@sammic.com



Project	Date
Item	Qty
Approved	

product sheet
updated 06/06/2023