



# GLASSWASHER GP-50 230/50/1

Rack size 500x500mm and door clearance 260 mm.

P/N 1303160



## ACCESSORIES

- Manual water softeners
- Automatic water softeners
- 500 x 500 mm. baskets
- Inserts & supplements
- High feet kit
- Reverse osmosis device OS-140P
- Detergent dosing equipment for GP glasswashers

## SPECIFICATIONS

Basket dimensions: 500 mm x 500 mm  
Useful height: 260 mm

Cycle duration: 90 / 120 “  
Production baskets/hour: 45 / 30

Boiler capacity: 4.5 l  
Wash tank capacity: 23 l  
Water consumption/cycle: 2.7 l

### Loading

- ✓ Pump: 550 W / 0.75 Hp
- ✓ Tank: 1800 W
- ✓ Boiler: 2800 W
- ✓ Total loading: 3350 W

Electrical supply: 230 V / 50 Hz / 1 ~ (14.6 A)  
Electrical connection: 2P+G

### External dimensions (WxDxH)

- ✓ Width: 580 mm
  - ✓ Depth: 630 mm
  - ✓ Height: 710 mm
- Net weight: 52 Kg  
Noise level (1m.): -- dB(A)

## SALES DESCRIPTION

### Sani-Control guarantee

- ✓ GUARANTEED DISINFECTION in compliance with standard DIN 10534.
- ✓ THERMAL LOCK function: Ensures that rinsing will be carried out at the ideal temperature to disinfect the dishes.
- ✓ Upper and lower washing.
- ✓ Construction in stainless steel AISI 304 2B.
- ✓ Interior with rounded finishes to prevent the accumulation of dirt.

### Double filter system

- ✓ Maximum protection of the washing pump.

### Double-walled door

- ✓ Double-walled door, safety microswitch and high quality seal: perfectly soundproof and watertight.

### Warewashing, made simple

- ✓ GP Xperience: simple and intuitive use.
- ✓ Dedicated cycles: selection of the ideal washing programme using icons.
- ✓ Electronic control panel with IP65 humidity protection.
- ✓ 100% Tested.

### Tech-friendly

- ✓ Tool-free extraction of diffusers and filters for maintenance and cleaning
- ✓ Easy access to components for repair.

## INCLUDES

- ✓ Rinse aid pump.
- ✓ 1 glasses basket.
- ✓ 1 mixed basket (plates).
- ✓ 1 small basket for cutlery.

## OPTIONAL

- Detergent dosing kit.



WARE WASHING  
COMMERCIAL GLASSWASHER • GLASS-PRO LINE

product sheet  
updated 06/06/2023



# GLASSWASHER GP-50 230/50/1

Rack size 500x500mm and door clearance 260 mm.



P/N 1303160

WARE WASHING  
COMMERCIAL GLASSWASHER · GLASS-PRO LINE

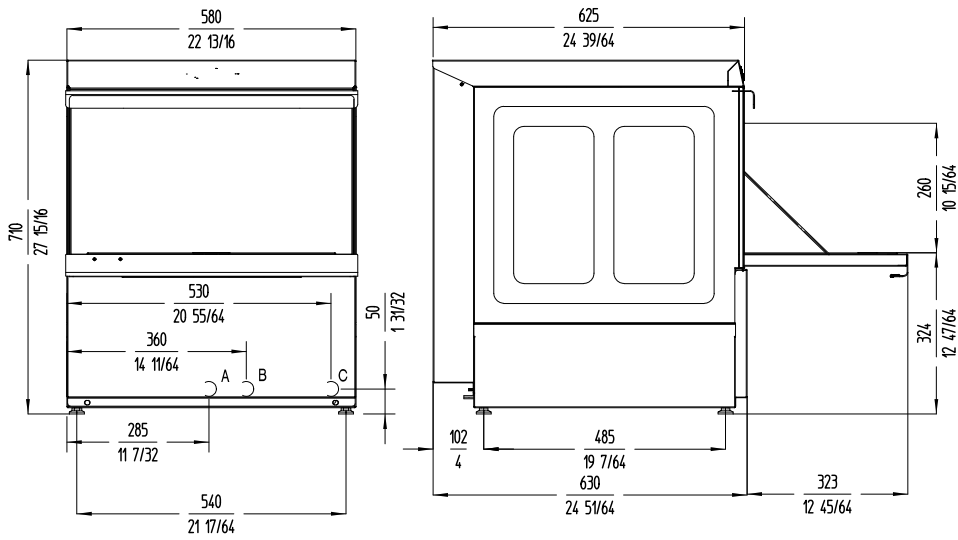

A: Entrada de agua 3/4" GAS.  
B: Tubo de desagüe ø30 mm.  
C: Cable conexión.

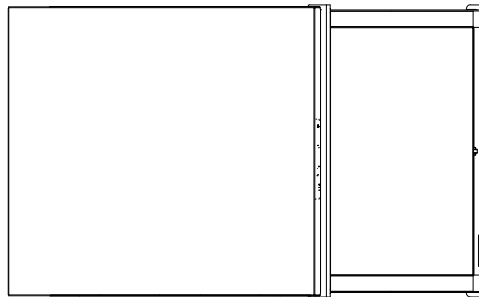

**sammic** | www.sammic.com  
Food Service Equipment Manufacturer

Polígono Basarte, 1. phone +34 943 15 72 36  
20720 Azkoitia, Spain sales@sammic.com



Project	Date
Item	Qty
Approved	

product sheet  
updated 06/06/2023