



VACUUM PACKING MACHINE SU-810P CC 400/50-60/3N

Floorstanding unit. 100m³/h. 581+581 mm.



P/N 1140948



SALES DESCRIPTION

Two sealing bars (581+581 mm.)
100 m³/h Busch vacuum pump.
Vacuum controlled by sensor.

- ✓ Powered by Busch.
- ✓ Vacuum controlled by sensor.
- ✓ Vacuum PLUS.
- ✓ LCD colour screen: all information at a glance.
- ✓ Backlit touch keyboard.
- ✓ Programmable: 25-programme memory. Blocking option.
- ✓ "Pause" button.
- ✓ Phased vacuum programme.
- ✓ Detection of the evaporation of liquids.
- ✓ Double seal.
- ✓ Cordless sealing bar.
- ✓ Progressive decompression.
- ✓ Vac-Norm ready with Automatic decompression.
- ✓ Stainless steel body and chamber.
- ✓ Damped transparent lid.
- ✓ Dry-oil programme for drying the pump.
- ✓ Working hours counter for oil changes.
- ✓ Safety system with protection against vacuum failure.
- ✓ NSF-listed.

INCLUDES

- ✓ Filling plate
- ✓ Printer connection
- ✓ Wireless connectivity

OPTIONAL

- Printer
- Vacuum packing pouches
- Vac-Norm external vacuum kit, containers and accessories
- Bag cutting kit
- Support for liquids
- Additional filling plates

ACCESSORIES

- Bag cutting kits
- Filling plates
- Liquid insert plates
- Vac-norm external vacuum kits
- Vac-norm containers
- Smooth bags for vacuum packing
- Thermal labels for CG2 / RB printer
- RB desktop printer for SU vacuum packing machines
- Thermal transfer labels for RB printer

SPECIFICATIONS

Pump capacity: 100 m³/h
 Pump capacity (60 Hz): 120 m³/h
 Bar length: 581 mm + 581 mm
 Total loading: 2200 W
 Vacuum pressure (maximum): 0.5 mbar
 Electrical supply: 400 V- / 50-60 Hz / 3N~ (8.7 A)
 Electrical connection: 3P+N+G

Internal dimensions

- ✓ Width: 864 mm
- ✓ Depth: 603 mm
- ✓ Height: 215 mm

External dimensions (W x D x H)

- ✓ Width: 960 mm
- ✓ Depth: 757 mm
- ✓ Height: 998 mm

Net weight: 250 kg

Noise level (1m.): 75 dB(A)
 Background noise: 32 dB(A)

Crated dimensions

840 x 1060 x 1200 mm
 Gross weight: 291 kg

FOOD PRESERVATION AND SOUS-VIDE
VACUUM PACKING MACHINES • SENSOR ULTRA LINE

product sheet
updated 24/05/2024





VACUUM PACKING MACHINE SU-810P CC 400/50-60/3N

Floorstanding unit. 100m³/h. 581+581 mm.



P/N 1140948

FOOD PRESERVATION AND SOUS-VIDE
VACUUM PACKING MACHINES • SENSOR ULTRA LINE

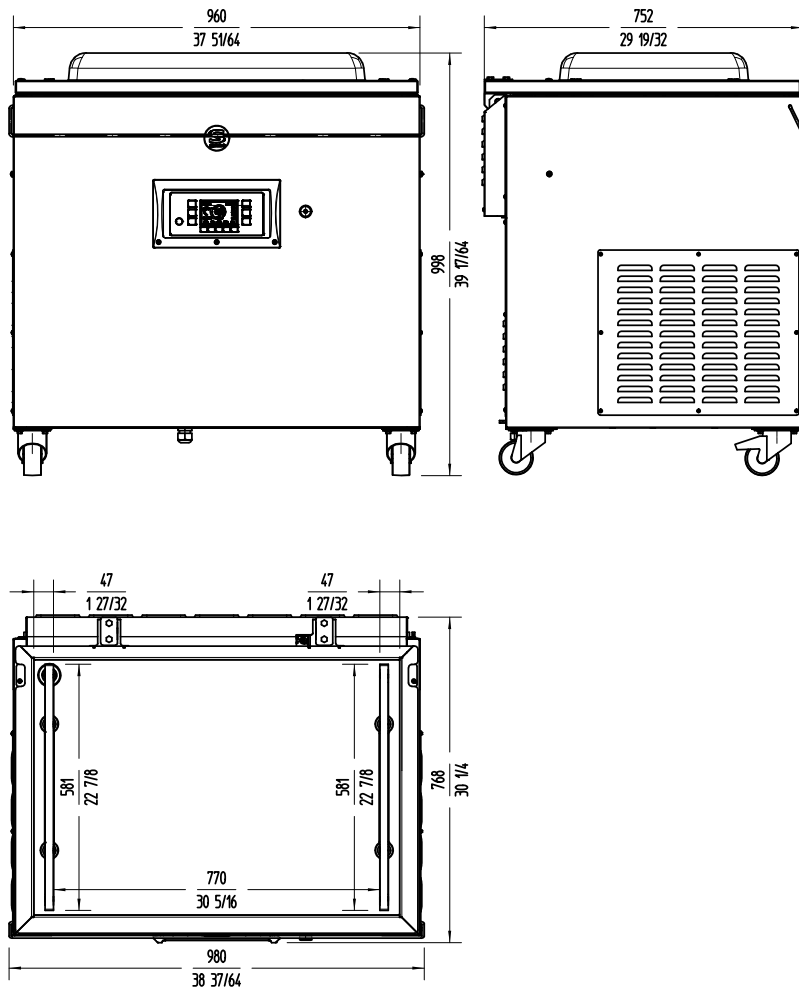

sammic | www.sammic.com
Food Service Equipment Manufacturer

Polígono Basarte, 1. phone +34 943 15 72 36
 20720 Azkoitia, Spain sales@sammic.com



Project	Date
Item	Qty
Approved	

product sheet
updated 24/05/2024